

2

Kinematics: The Mathematics of Motion

2.1 Motion in One Dimension

1. Sketch position-versus-time graphs for the following motions. Include a numerical scale on both axes with units that are *reasonable* for this motion. Some numerical information is given in the problem, but for other quantities make reasonable estimates.

Note: A *sketched* graph simply means hand-drawn, rather than carefully measured and laid out with a ruler. But a sketch should still be neat and as accurate as is feasible by hand. It also should include labeled axes and, if appropriate, tick-marks and numerical scales along the axes.

- a. A student walks to the bus stop, waits for the bus, then rides to campus. Assume that all the motion is along a straight street.

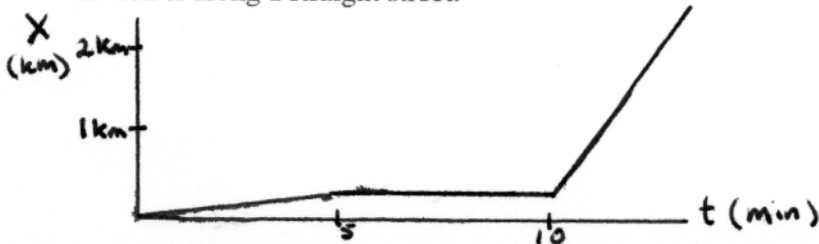

- b. A student walks slowly to the bus stop, realizes he forgot his paper that is due, and *quickly* walks home to get it.

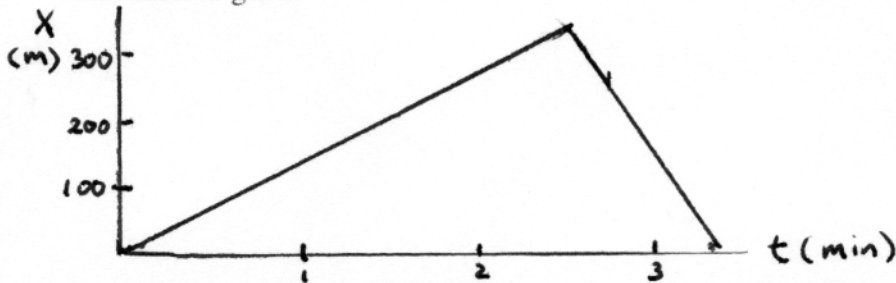

- c. The quarterback drops back 10 yards from the line of scrimmage, then throws a pass 20 yards to the tight end, who catches it and sprints 20 yards to the goal. Draw your graph for the *football*. Think carefully about what the slopes of the lines should be.

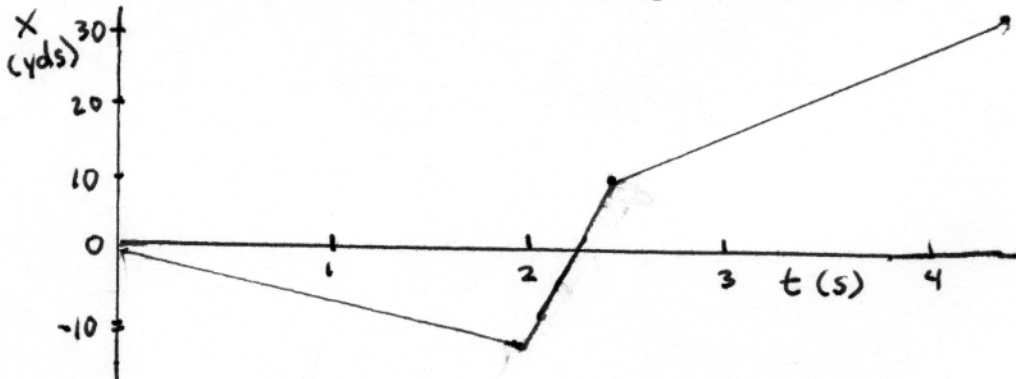

2. Interpret the following position-versus-time graphs by writing a very short “story” of what is happening. Be creative! Have characters and situations! Simply saying that “a car moves 100 meters to the right” doesn’t qualify as a story. Your stories should make *specific reference* to information you obtain from the graphs, such as distances moved or time elapsed.

a. Moving car

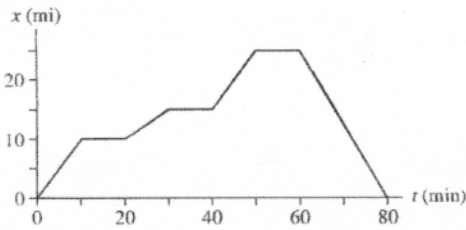

It was a typical summer day on the interstate. After driving for 10 min at 60 mph, I stopped at a rest area for coffee. When I got back on the road 10 min later, I was slowed to 30 mph by a construction zone for 10 min, then stopped entirely for another 10 min. Finally, back up to cruising speed, I got off at my exit 25 miles from home. After searching my pockets and car for 10 min I realized that I left my wallet at home so I drove back, without stops or construction delays, at 75 mph!

b. Sprinter

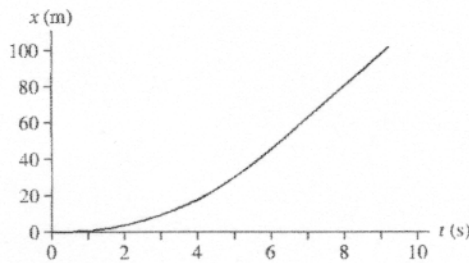

With a slow start out of the blocks, a super sprinter reached top speed in about 5 seconds, having gone only 30 meters. He still was able to finish his 100m in only just over 9s. by running a world record pace for the rest of the race.

c. Submarine

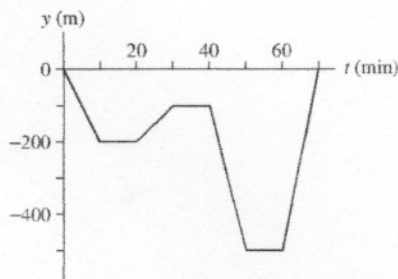

We made a slow dive to 200m as we entered enemy territory. After cruising for 10 minutes, we slowly rose up to 100m to listen for sounds from enemy ships. Oh no! We’ve been heard. In an evasive move to escape depth charges, we dive to 500m and make our way out to sea. Safe again, we rise to the surface.

d. Two football players

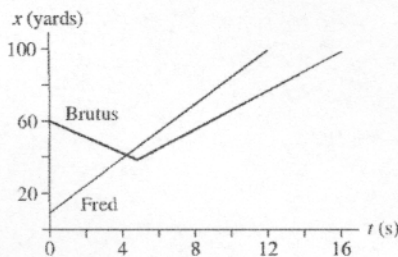

At the kickoff, Fred receives the ball on the 10 yd line and heads upfield at a sprint. Brutus runs towards Fred in an attempt to tackle him, but misses as Fred crosses the 50 yard line.

Brutus vainly tries to catch up, but Fred scores. Foolishly, Brutus continues to run after Fred has already scored.

3. Can you give an interpretation to this position-versus-time graph? If so, then do so. If not, why not?

There is no sensible interpretation because the graph requires the object to be in two places at once!

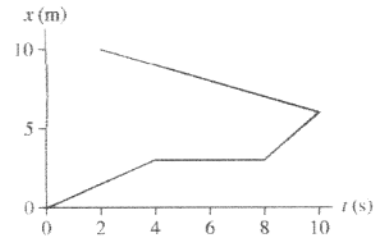

2.2 Uniform Motion

4. Sketch position-versus-time graphs for the following motions. Include appropriate numerical scales along both axes. A small amount of computation may be necessary.

- a. A parachutist opens her parachute at an altitude of 1500 m. She then descends slowly to earth at a steady speed of 5 m/s. Start your graph as her parachute opens.

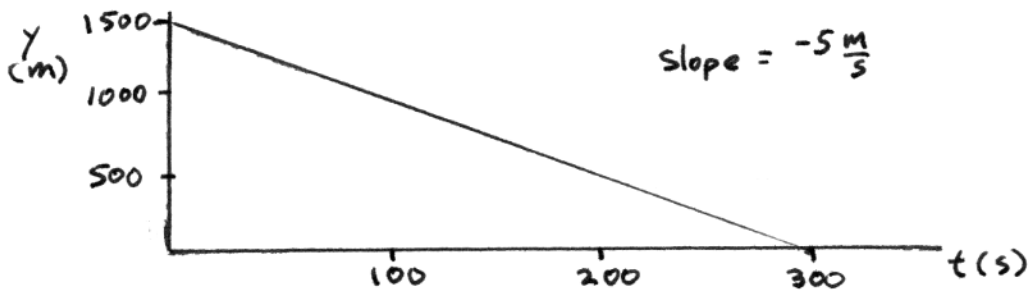

- b. Trucker Bob starts the day 120 miles west of Denver. He drives east for 3 hours at a steady 60 miles/hour before stopping for his coffee break. Let Denver be located at $x = 0$ mi and assume that the x -axis points to the east.

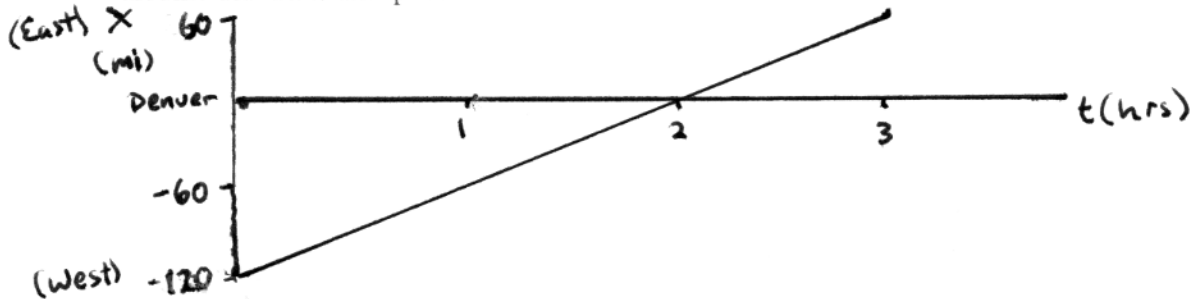

- c. Quarterback Bill throws the ball to the right at a speed of 15 m/s. It is intercepted 45 m away by Carlos, who is running to the left at 7.5 m/s. Carlos carries the ball 60 m to score. Let $x = 0$ m be the point where Bill throws the ball. Draw the graph for the football.

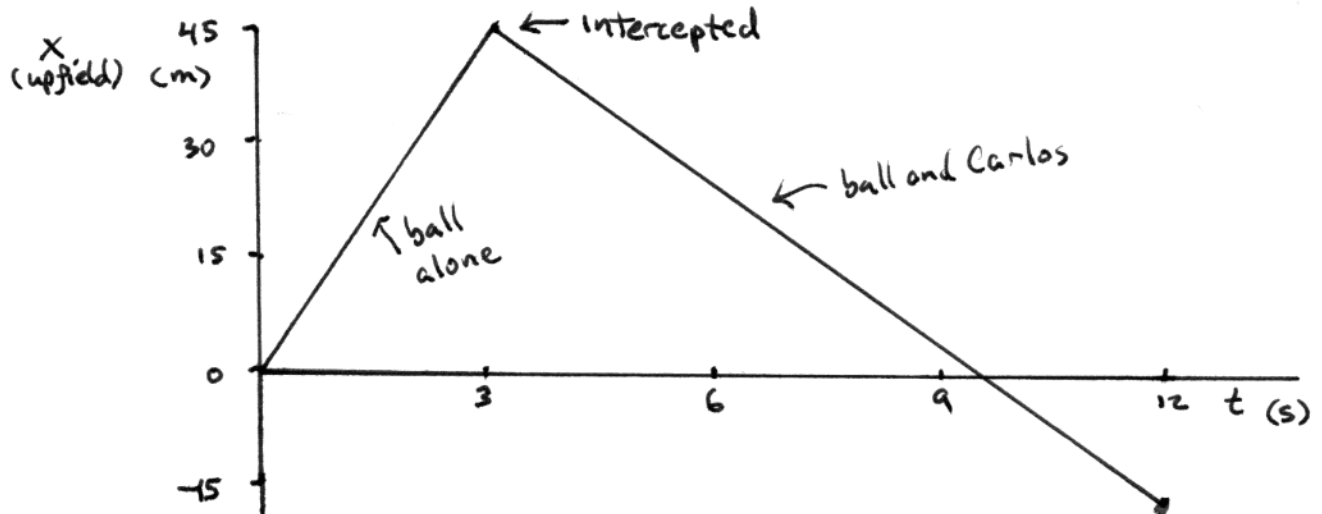

5. The figure shows a position-versus-time graph for the motion of objects A and B that are moving along the same axis.

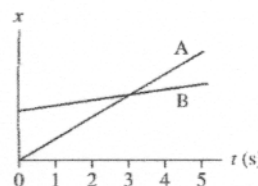

a. At the instant $t = 1$ s, is the speed of A greater than, less than, or equal to the speed of B? Explain.

At $t = 1$ s, the slope of the line for A is greater than that for object B. Therefore, object A's speed is greater. (Both are positive slopes.)

b. Do objects A and B ever have the same speed? If so, at what time or times? Explain.

No, the speeds are never the same. Each has a constant speed (constant slope) and A's speed is always greater.

6. Interpret the following position-versus-time graphs by writing a short "story" about what is happening. Your stories should make specific references to the *speeds* of the moving objects, which you can determine from the graphs. Assume that the motion takes place along a horizontal line.

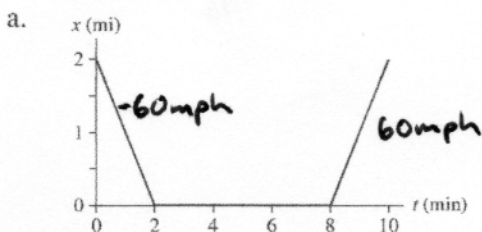

On a quick trip on the interstate, Jimmy drives west for two miles at 60 mph, stops at an exit for 6 minutes, then returns east at 60 mph to where he started.

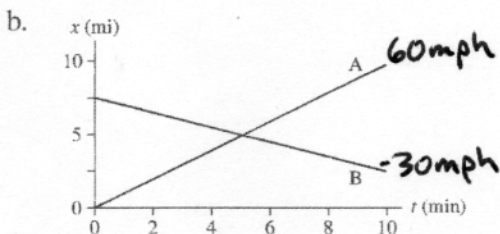

A takes the interstate east for 10 miles at 60 mph. B starts 7.5 miles east and takes a parallel slower road west at 30 mph during the same time.

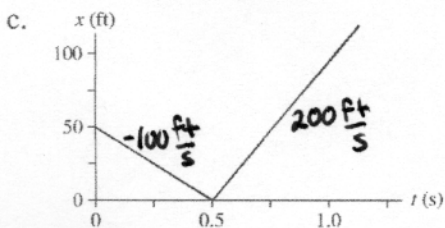

Starting 10 ft in front of home plate, Bob pitched a change-up to Sammy at 100 ft/s. Sammy drove it straight back at him at 200 ft/s.

2.3 Instantaneous Velocity

7. Draw both a position-versus-time graph *and* a velocity-versus-time graph for an object that is at rest at $x = 1$ m.

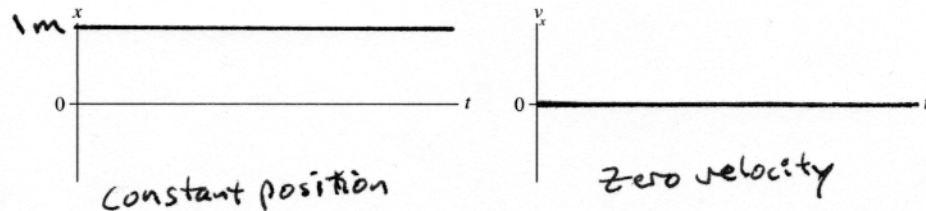

8. The figure shows the position-versus-time graphs for two objects, A and B, that are moving along the same axis.

- a. At the instant $t = 1$ s, is the speed of A greater than, less than, or equal to the speed of B? Explain.

A's speed is greater at $t = 1$ s. The slope of the tangent to B's curve at $t = 1$ s is smaller than the slope of A's line.

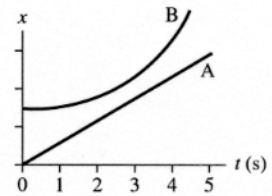

- b. Do objects A and B ever have the *same* speed? If so, at what time or times? Explain.

A and B have the same speed at just before $t = 3$ s. At that time, the slope of the tangent to the curve representing B's motion is equal to the slope of the line representing A.

9. Below are six position-versus-time graphs. For each, draw the corresponding velocity-versus-time graph directly below it. A vertical line drawn through both graphs should connect the velocity v_s at time t with the position s at the *same* time t . There are no numbers, but your graphs should correctly indicate the *relative* speeds.

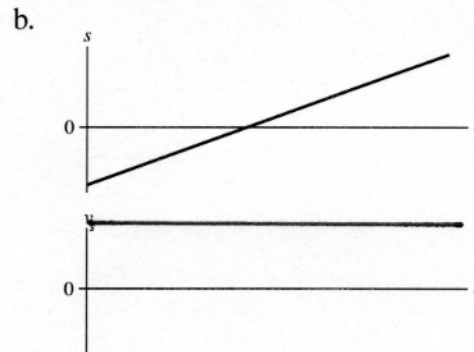
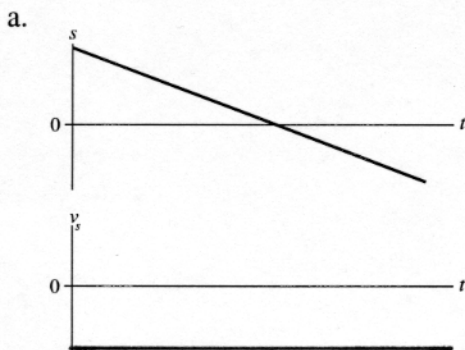

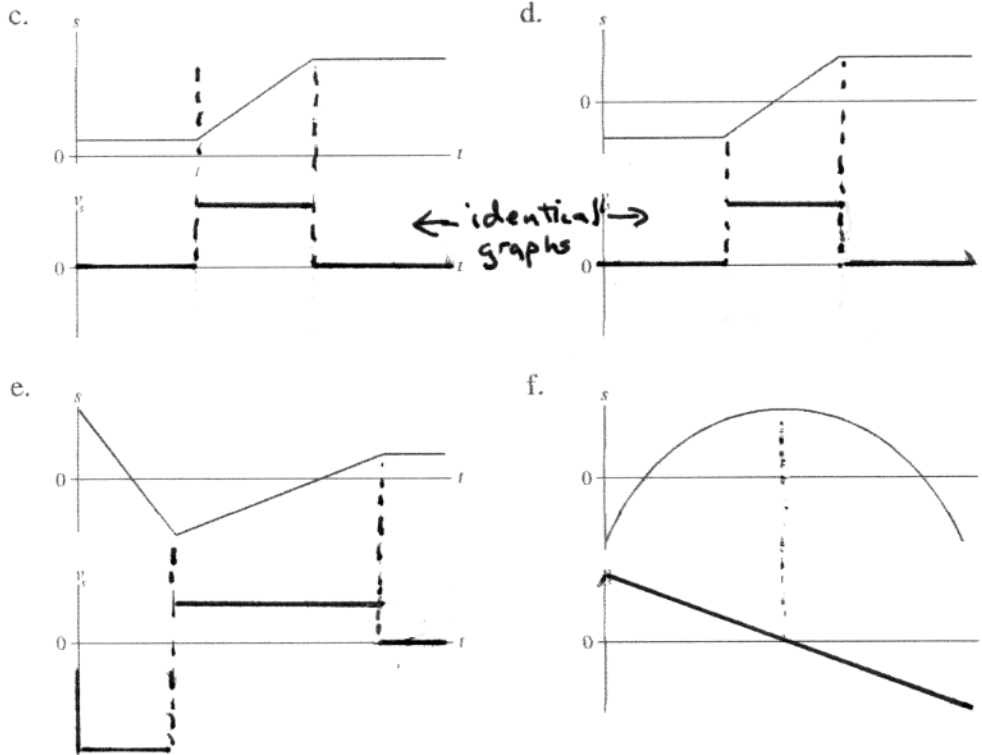

10. The figure shows a position-versus-time graph for a moving object. At which lettered point or points:

- a. Is the object moving the slowest? B
- b. Is the object moving the fastest? D
- c. Is the object at rest? A, C, E
- d. Does the object have a constant nonzero velocity? B, D
- e. Is the object moving to the left? D

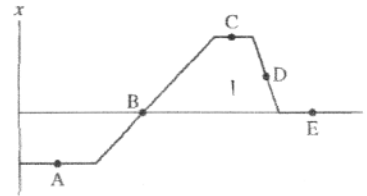

11. The figure shows a position-versus-time graph for a moving object. At which lettered point or points:

- a. Is the object moving the fastest? D
- b. Is the object moving to the left? C, D, E
- c. Is the object speeding up? C
- d. Is the object slowing down? A, E
- e. Is the object turning around? B

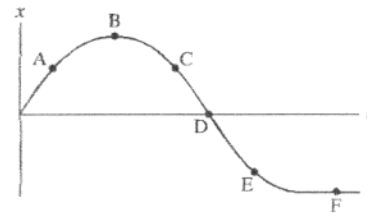

12. For each of the following motions, draw

- A motion diagram,
- A position-versus-time graph, and
- A velocity-versus-time graph.

a. A car starts from rest, steadily speeds up to 40 mph in 15 s, moves at a constant speed for 30 s, then comes to a halt in 5 s.

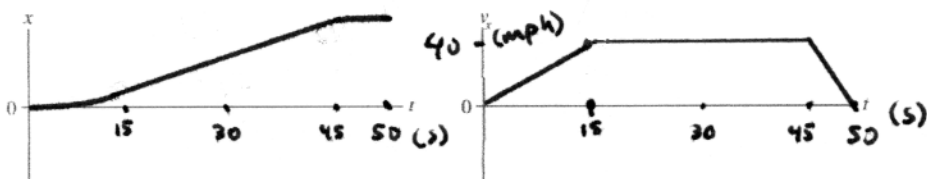
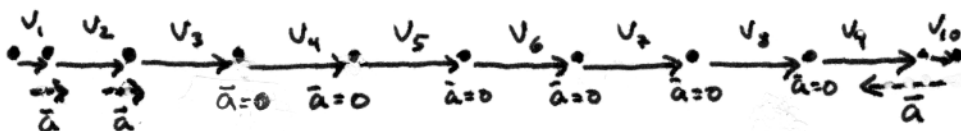

b. A rock is dropped from a bridge and steadily speeds up as it falls. It is moving at 30 m/s when it hits the ground 3 s later. Think carefully about the signs.

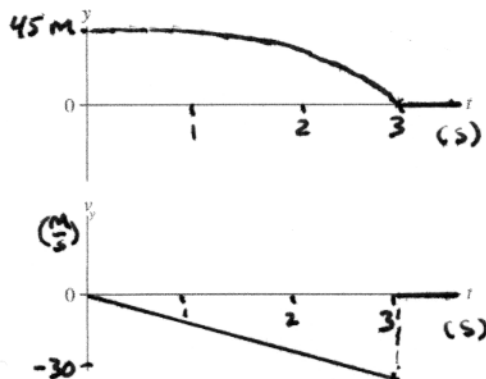
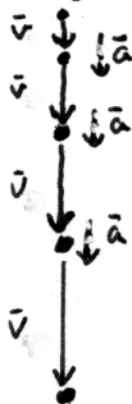

c. A pitcher winds up and throws a baseball with a speed of 40 m/s. One-half second later the batter hits a line drive with a speed of 60 m/s. The ball is caught 1 s after it is hit. From where you are sitting, the batter is to the right of the pitcher. Draw your motion diagram and graph for the *horizontal* motion of the ball.

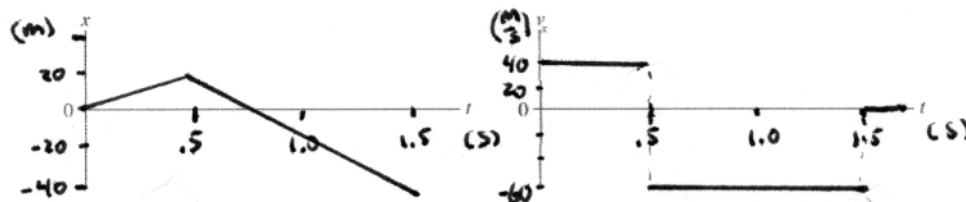
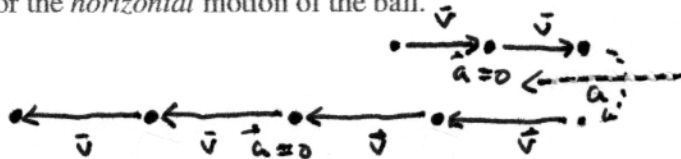

13. The figure shows six frames from the motion diagram of two moving cars, A and B.



- a. Draw both a position-versus-time graph and a velocity-versus-time graph. Show the motion of *both* cars on each graph. Label them A and B.

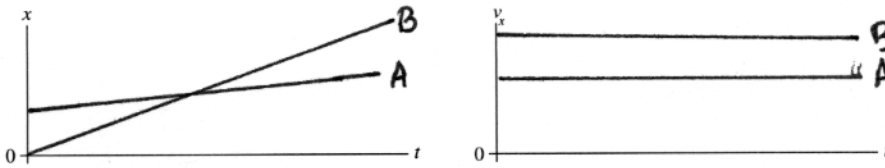

b. Do the two cars ever have the same position at one instant of time?

If so, in which frame number (or numbers)? yes, at 3

Draw a vertical line through your graphs of part a to indicate this instant of time.

c. Do the two cars ever have the same velocity at one instant of time?

If so, between which two frames? No

14. The figure shows six frames from the motion diagram of two moving cars, A and B.

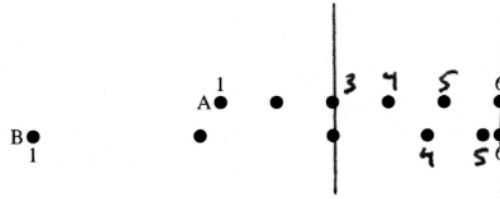

- a. Draw both a position-versus-time graph and a velocity-versus-time graph. Show *both* cars on each graph. Label them A and B.

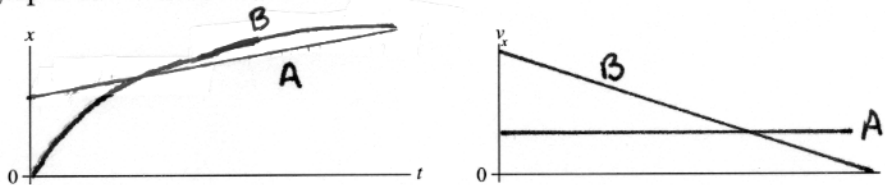

b. Do the two cars ever have the same position at one instant of time?

If so, in which frame number (or numbers)? Yes, at 3 and at 6

Draw a vertical line through your graphs of part a to indicate this instant of time.

c. Do the two cars ever have the same velocity at one instant of time?

If so, between which two frames? yes, from 4 to 5

15. You're driving along the highway at a steady speed of 60 mph when another car decides to pass you. At the moment when the front of his car is exactly even with the front of your car, and you turn your head to smile at him, do the two cars have equal velocities? Explain.

No, though you have the same position along the road, his velocity is greater because he is passing you. If his velocity were not greater, then he would remain even with the front of your car.

2.4 Finding Position from Velocity

16. Below are shown four velocity-versus-time graphs. For each:

- Draw the corresponding position-versus-time graph.
- Give a written description of the motion.

Assume that the motion takes place along a horizontal line and that $x_0 = 0$.

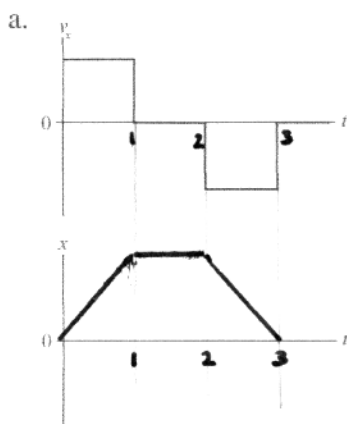

- Moving forward at constant speed for the first one-third.
- Remaining stationary for the second one-third of the time.
- Moving backward at the same speed for the final third.

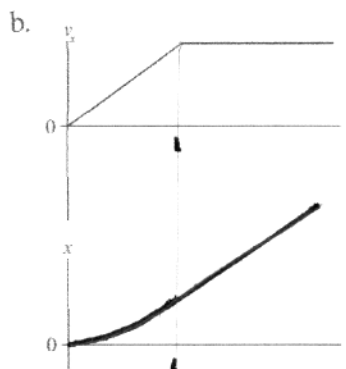

- Speeding up initially and then maintaining a constant speed after point 1.

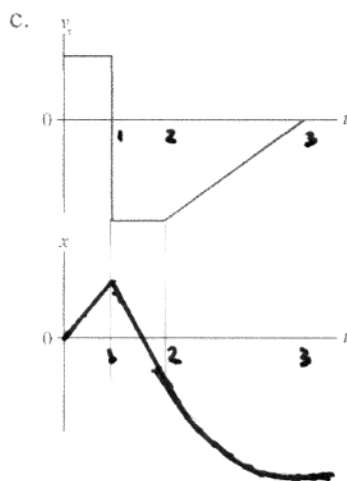

- Constant forward speed to 1
- A greater constant speed backwards from 1 to 2.
- Slowing down while moving backwards from 2 to 3, and stopping at 3.

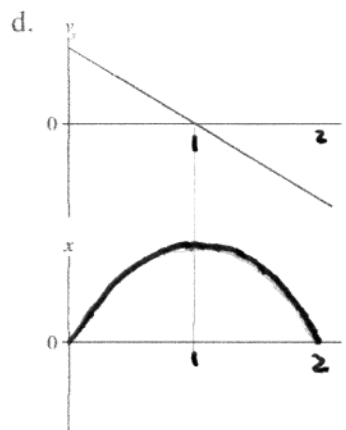

- Constant negative acceleration. Slowing down until 1 and then turning around and speeding up to return to the starting point at 2.

17. The figure shows the velocity-versus-time graph for a moving object whose initial position is $x_0 = 20$ m. Find the object's position graphically, using the geometry of the graph, at the following times. **Finding the area under the curve.**

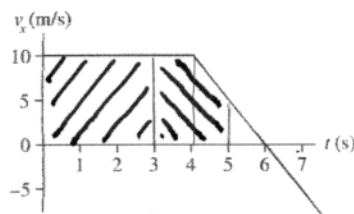

- a. At $t = 3$ s.

Use the rectangle marked **//**.

$$X(3s) = X_0 + V_x(0-3s)(3s)$$

$$= 20\text{m} + 10\frac{\text{m}}{\text{s}}(3s) = \boxed{50\text{m}}$$

- b. At $t = 5$ s. Add to the previous answer the area marked **///**.
This area can be found by adding the rectangle from 3s to 4s and $\frac{3}{4}$ of that area for the portion from 4s to 5s. Or, equivalently,

$$X(5s) = 50\text{m} + V_x(3s-4s)(1s) + \frac{1}{2}(V_x(4s) + V_x(5s))(1s)$$

$$= 50\text{m} + 10\frac{\text{m}}{\text{s}}(1s) + \frac{1}{2}(10\frac{\text{m}}{\text{s}} + 5\frac{\text{m}}{\text{s}})(1s) = 50\text{m} + 10\text{m} + 7.5\text{m}$$

$$= \boxed{67.5\text{m}}$$

- c. At $t = 7$ s.

Add to the previous answer the area of the triangle from 5s to 6s and subtract the area of the triangle from 6s to 7s. These areas are $\frac{1}{2}5\frac{\text{m}}{\text{s}}(1s) + \frac{1}{2}(-5\frac{\text{m}}{\text{s}})(1s)$.
So, $X(7s) = 67.5\text{m} + 2.5\text{m} - 2.5\text{m} = \boxed{67.5\text{m}}$

- d. You should have found a simple relationship between your answers to parts b and c. Can you explain this? What is the object doing?

During the time from 5s to 7s, the object is slowing while moving in the $+X$ direction for 1 second, then speeding up while moving in the $-X$ direction for the second-second. Because the acceleration is constant and the times are equal, the motion is symmetric. The object retraces its path in reverse. Time $t = 6s$ is a turning point.

2.5 Motion with Constant Acceleration

18. A car is traveling north. Can its acceleration vector ever point south? Explain.

Yes. The acceleration vector will point south when the car is slowing down while traveling north.

19. Give a specific example for each of the following situations. For each, provide:

- A description, and
- A motion diagram.

a. $a_x = 0$ but $v_x \neq 0$. **Traveling at constant velocity**

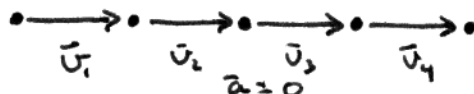

b. $v_x = 0$ but $a_x \neq 0$. **Turning around**

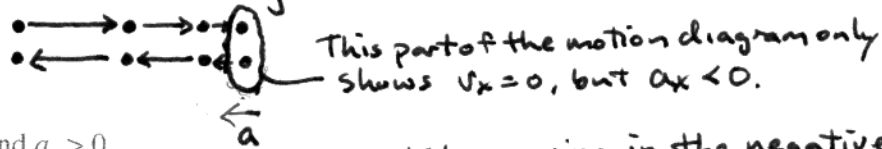

c. $v_x < 0$ and $a_x > 0$. **Slowing down while moving in the negative direction.**

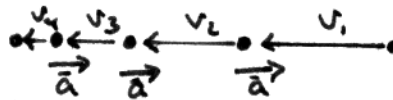

20. Below are three velocity-versus-time graphs. For each:

- Draw the corresponding acceleration-versus-time graph.
- Draw a motion diagram below the graphs.

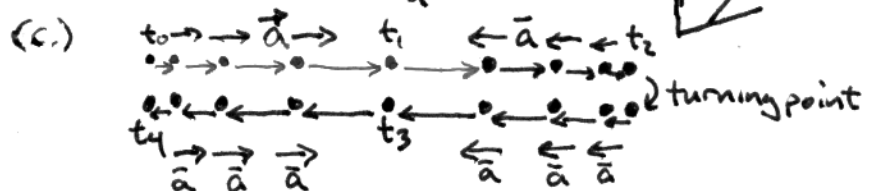
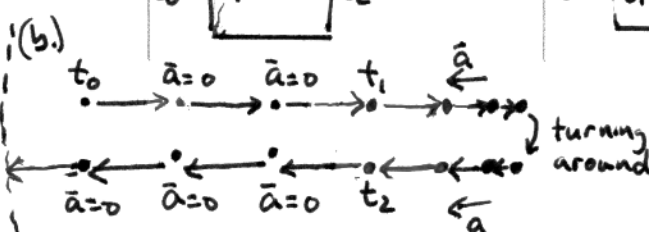
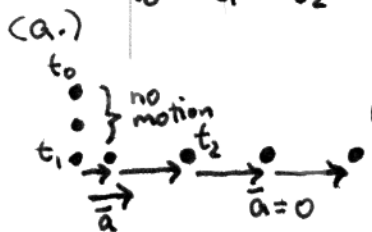
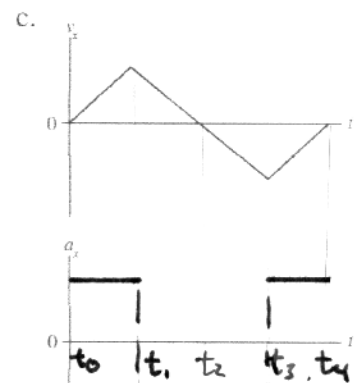
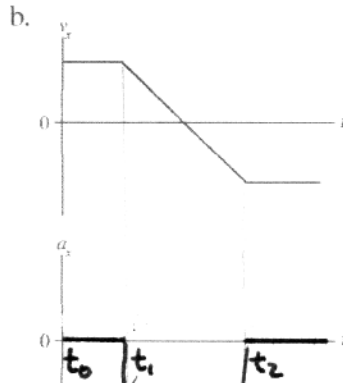
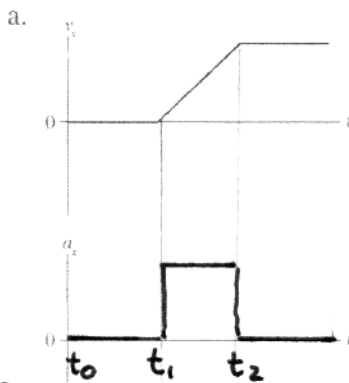

21. Below are three acceleration-versus-time graphs. For each, draw the corresponding velocity-versus-time graph. Assume that $v_{0x} = 0$.

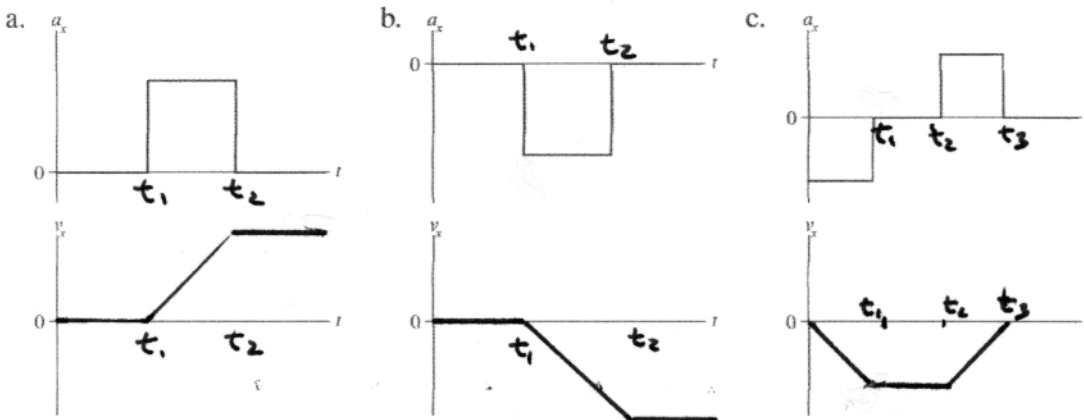

22. The figure below shows nine frames from the motion diagram of two cars. Both cars begin to accelerate, with constant acceleration, in frame 4.

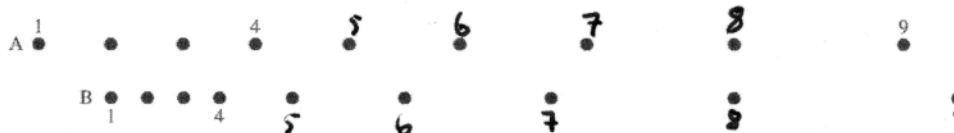

- a. Which car has the largest initial velocity? A The largest final velocity? B
 b. Which car has the largest acceleration after frame 4? How can you tell?

B B's acceleration must be greater to go from a smaller initial velocity to a larger final velocity. The change in spacing between successive frames is greater for B.

c. Draw position, velocity, and acceleration graphs, showing the motion of both cars on each graph. (Label them A and B.) This is a total of three graphs with two curves on each.

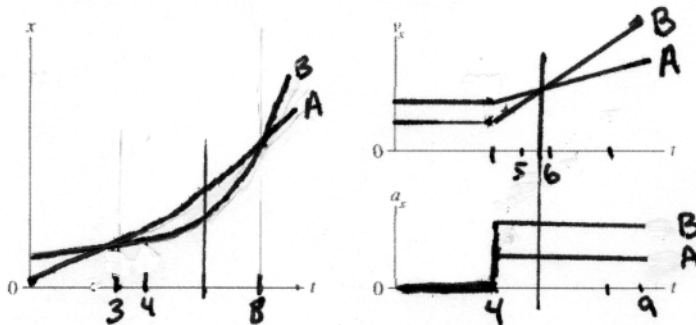

d. Do the cars ever have the same position at one instant of time? If so, in which frame? 3 and 8

e. Do the two cars ever have the same velocity at one instant of time?

If so, identify the *two* frames between which this velocity occurs. 5-6

Identify this instant on your graphs by drawing a vertical line through the graphs. see lines

2.6 Free Fall

23. A ball is thrown straight up into the air. At each of the following instants, is the ball's acceleration g , $-g$, 0 , $< g$, or $> g$?

- a. Just after leaving your hand? $-g$
- b. At the very top (maximum height)? $-g$
- c. Just before hitting the ground? $-g$

24. A rock is *thrown* (not dropped) straight down from a bridge into the river below.

- a. Immediately *after* being released, is the magnitude of the rock's acceleration greater than g , less than g , or equal to g ? Explain.

The magnitude of the acceleration while in free fall is equal to g at all times, independent of the initial velocity. The acceleration only tells how the velocity is changing.

- b. Immediately before hitting the water, is the magnitude of the rock's acceleration greater than g , less than g , or equal to g ? Explain.

The magnitude of the acceleration is still g because the rock is still in free fall. The speed is increasing at the same rate each instant, that is, by the same Δv each second.

25. Alicia throws a red ball straight up into the air, releasing it with velocity v_0 . As she is throwing it, you happen to pass by in an elevator that is rising with constant velocity v_0 . At the exact instant Alicia releases her ball, you reach out of the elevator's window (this is a very fancy elevator!) and *gently* release a blue ball. Both balls are the same height above the ground at the moment they are released.

- a. Describe the motion of the two balls as Alicia sees them from the ground. In what ways are the motion of the red ball and the blue ball the same or different?

Alicia sees no difference in the motion of the two balls. Both slow while rising then, at identical heights, they reach their peak and begin to speed up on their way down. The blue ball has the initial upward velocity of the elevator which is the same as the initial velocity of the red ball.

- b. Describe the motion of the two balls as you see them from the moving elevator. In what ways are the motion of the red ball and the blue ball the same or different?

You see their motions as being identical. Both balls are falling away from you at increasing speed, with constant acceleration, $-g$. From your perspective, both balls start from rest and are in free fall.

- c. Alicia sees a well-defined "top" of the motion where her red ball reaches a maximum height and then starts to fall. Call the time of maximum height t_1 . As you watch from the elevator, do you see anything distinctive or different about the red ball's motion at time t_1 ? If so, what?

You do not see anything different about the balls' motion at t_1 . From your perspective, both balls continue to fall away with increasing speed. The ground appears to move away from you at constant velocity. At the instant t_1 , the balls happen to be moving away from you at the same speed as the ground.

- d. Does the red ball "stop" at time t_1 when Alice sees it at the very top of its trajectory? As part of answering this question, define what you mean by the word "stop."

If one defines stopping as having a velocity of zero, if only for an instant, then Alice sees the red ball (and the blue ball) "stop" at the top of its trajectory. Because the velocity observed depends upon the observer's motion, you do not see the balls stop at any time after they begin their motion.

2.7 Motion on an Inclined Plane

26. A ball released from rest on an inclined plane accelerates down the plane at 2 m/s^2 . Complete the table below showing the ball's velocities at the times indicated. Do *not* use a calculator for this; this is a reasoning question, not a calculation problem.

Time (s)	Velocity (m/s)
0	0
1	<u>2 m/s</u>
2	<u>4 m/s</u>
3	<u>6 m/s</u>
4	<u>8 m/s</u>
5	<u>10 m/s</u>

(If we define up the plane as the positive direction, then the velocities are all negative.)

27. A bowling ball rolls along a level surface, then up a 30° slope, and finally exits onto another level surface at a much slower speed.

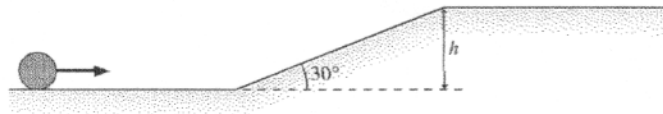

a. Draw position-, velocity-, and acceleration-versus-time graphs for the ball.

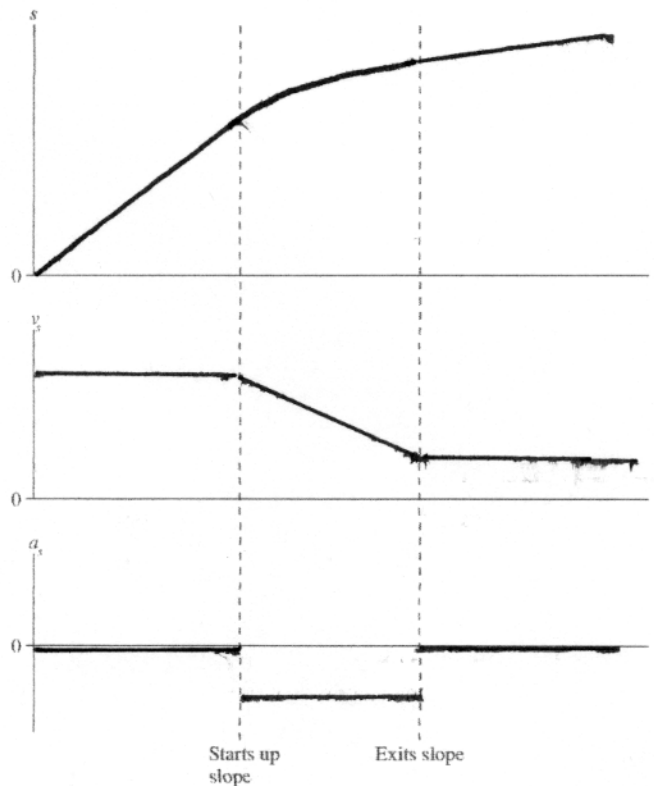

- b. Suppose that the ball's initial speed is 5.0 m/s and its final speed is 1.0 m/s. Draw a pictorial representation that you would use to determine the height h of the slope. Establish a coordinate system, define all symbols, list known information, and identify desired unknowns.

Note: Don't actually solve the problem. Just draw the complete pictorial representation that you would use as a first step in solving the problem.

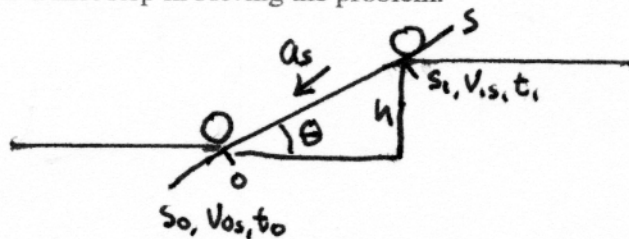

Known:

$$s_0 = 0 \text{ m (at start of slope)}$$

$$t_0 = 0 \text{ s}$$

$$\theta = 30^\circ$$

$$v_{0s} = 5 \frac{\text{m}}{\text{s}}$$

$$v_{1s} = 1 \frac{\text{m}}{\text{s}}$$

$$a_s = -g \sin \theta$$

$$\Delta s = h / \sin \theta$$

Find
 h

2.8 Instantaneous Acceleration

28. Below are two acceleration-versus-time curves. For each, draw the corresponding velocity-versus-time curve. Assume that $v_{0x} = 0$.

